

ALUMINUM HOUSED WIREWOUND RESISTORS

Series : **AL**

Features:

- Aluminum heat sink housing
- Complete welded construction
- Available in non-inductive style (type **AL-N**)
either Aryton- Perry winding for lowest reactive components
- Mounts on chassis to utilize heat-sink effect
- Wattage from **5 Watts to 5000 Watts**
- Any custom value or custom design available
- **RoHS** Compliant directive 2002/95/EC
- Lead (Pb)-free solder contacts.

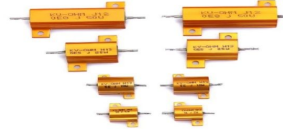

Technical specification:

DESCRIPTION	SERIES
	AL5 ~ AL5000
Resistance range*	0.1Ω ~ 1KΩ
Resistance tolerance	±1% ~ ±5%
Temperature coefficient	≤ 200 ppm/°C
Maximum dissipation @ 25°C	5W ~ 10000W
Maximum permissible voltage	√P X R
Insulation resistance	10 ³ MΩ at 500 V dc
Stability, ΔR max.	
Load	ΔR±(5.0% +0.05Ω)
Climatic test	ΔR±(5.0% +0.05Ω)
Soldering	ΔR±(0.5% +0.05Ω)
Short time overload	ΔR±(2.0% +0.05Ω)

Standard electrical specification:

TYPE	POWER RATING @ 25°C(W)		RESISTANCE RANGE (IN Ω)	TOLERANCE (IN %)	WEIGHT TYPICAL (IN g)
	WITH HEAT SINK	FREE AIR			
AL5	5W	2.5W	0.1Ω ~ 1KΩ	±1%(F), ±5%(J)	4 g
AL10	10W	5W	0.1Ω ~ 1KΩ	±1%(F), ±5%(J)	8 g
AL25	25W	12.5W	0.1Ω ~ 1KΩ	±1%(F), ±5%(J)	13 g
AL50	50W	25W	0.1Ω ~ 1KΩ	±1%(F), ±5%(J)	28 g
AL100	100W	50W	0.1Ω ~ 1KΩ	±1%(F), ±5%(J)	315 g
AL 150	150W	75W	0.1Ω ~ 1KΩ	±1%(F), ±5%(J)	420g
AL200	200W	100W	0.1Ω ~ 1KΩ	±1%(F), ±5%(J)	520 g
AL250	250W	125W	0.1Ω ~ 1KΩ	±1%(F), ±5%(J)	675g
AL300	300W	150W	0.1Ω ~ 1KΩ	±1%(F), ±5%(J)	830 g
AL 400	400W	200W	0.1Ω ~ 1KΩ	±1%(F), ±5%(J)	1050g
AL500	500W	250W	0.1Ω ~ 1KΩ	±1%(F), ±5%(J)	1270 g
AL 600	600W	300W	0.1Ω ~ 1KΩ	±1%(F), ±5%(J)	1600g
AL750	750W	375W	0.1Ω ~ 1KΩ	±1%(F), ±5%(J)	1900 g
AL1000	1000W	500W	0.1Ω ~ 1KΩ	±1%(F), ±5%(J)	2220 g
AL 1200	1200W	600W	0.1Ω ~ 1KΩ	±1%(F), ±5%(J)	2546g
AL 1400	1400W	700W	0.1Ω ~ 1KΩ	±1%(F), ±5%(J)	2880g
AL1500	1500W	750W	0.1Ω ~ 1KΩ	±1%(F), ±5%(J)	3200 g
AL2000	2000W	1000W	0.1Ω ~ 1KΩ	±1%(F), ±5%(J)	3500 g
AL2000S	2000W	1000W	0.1Ω ~ 1KΩ	±1%(F), ±5%(J)	3500 g
AL2500	2500W	1250W	0.1Ω ~ 1KΩ	±1%(F), ±5%(J)	5000g
AL3000	3000W	1500W	0.1Ω ~ 1KΩ	±1%(F), ±5%(J)	6000g
AL4000	4000W	2000W	0.1Ω ~ 1KΩ	±1%(F), ±5%(J)	7000g
AL5000	5000W	2500W	0.1Ω ~ 1KΩ	±1%(F), ±5%(J)	7800g

***Note :** Higher or low ohmic value other than resistance range & Non inductive type are available on request

Dimensions :1.0 AL5 & AL10

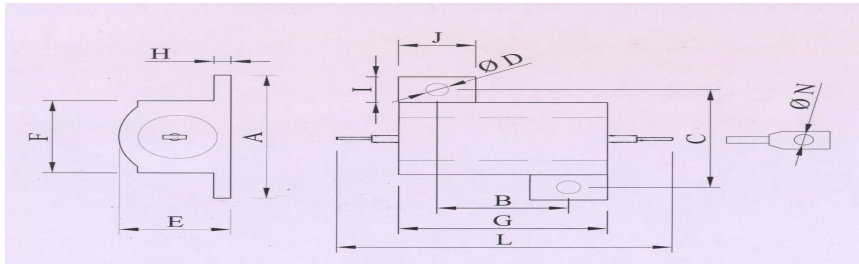

Physical Data:

1.0 SPECIFICATION FOR AL5 & AL10 :

TYPE	DIMENSIONS (MM)											
	A	B	C	D	E	F	G	H	I	J	L	N
AL 5	21 ±1	9.5 ±0.3	15 ±0.3	2.5 ±0.2	11 max.	10.5 ±1	15 ±1	1.5 ±0.3	6 max.	6.5 max.	30 max.	1.8 ±0.5
AL10	22 ±1	12.5 ±0.3	16 ±0.3	2.5 ±0.2	14 max.	12 ±1	19 ±1	1.8 ±0.3	6 max.	6.5 max.	35 max.	1.8 ±0.5

Dimensions :2.0 AL25 & AL50

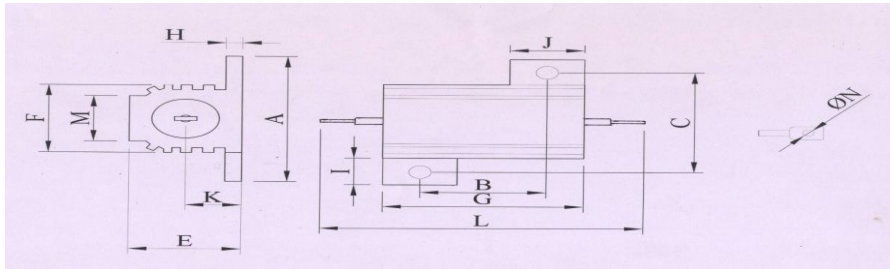

Physical Data:

2.0 SPECIFICATION FOR AL25 & AL50 :

TYPE	DIMENSIONS (MM)											
	A	B	C	D	E	F	G	H	I	J	L	N
AL 25	30 ±1	17 ±0.5	22.5 ±0.5	3.0 ±0.3	16 max.	16 ±1	27 ±2	2.0 ±0.5	8 max.	10 max.	52 max.	3 ±0.5
AL50	30 ±1	40 ±0.5	22.5 ±0.5	3.0 ±0.3	16.2 max.	16 ±1	50 ±2	2.5 ±0.5	9 max.	11 max.	72 max.	3 ±0.5

Dimensions :3.0 AL100 ~ AL2000

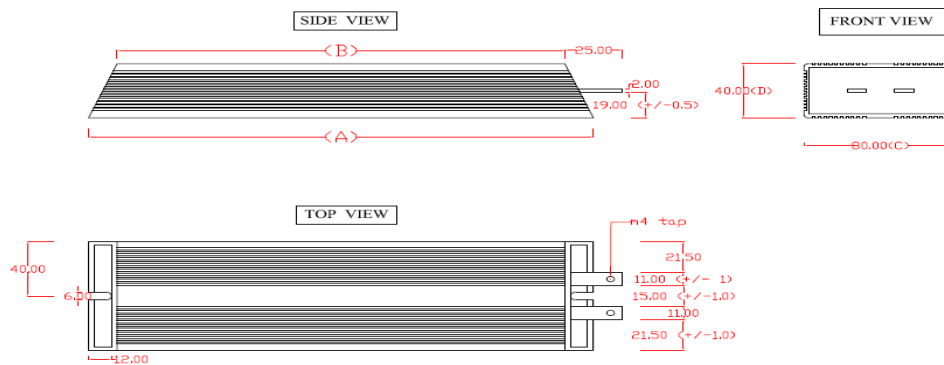

Physical Data:

3.0 SPECIFICATION FOR AL100 ~ AL2000 :

TYPE	DIMENSIONS (MM)			
	A Nominal	B Nominal	C ±5	D ±5
AL 100	100	70	60	30
AL 150	145	115	60	30
AL 200	165	135	60	30
AL 250	190	160	60	30
AL 300	215	185	60	30
AL400	265	235	60	30
AL 500	330	300	60	30
AL 600	265	235	80	40
AL 750	330	300	80	40
AL 1000	400	370	80	40
AL 1200	450	420	80	40
AL 1400	500	470	80	40
AL 1500	550	520	80	40
AL 2000	600	570	80	40

Dimensions :4.0 AL3000 ~ AL5000

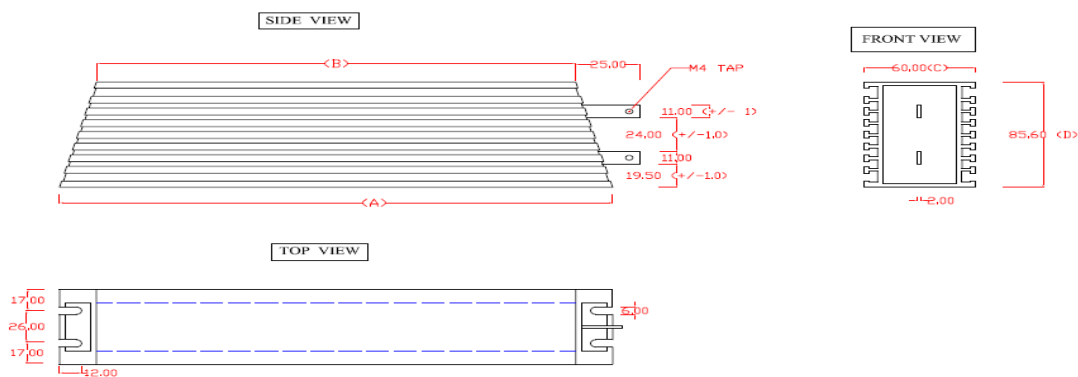

Physical Data:

1.0 SPECIFICATION FOR AL2000S & AL5000:

TYPE	DIMENSIONS (MM)			
	A Nominal	B Nominal	C ±5	D ±5
AL 2000S	430	400	60	85
AL 2500	450	420	60	85
AL 3000	500	470	60	85
AL 4000	600	570	60	85
AL 5000	700	670	60	85

Heat Sink Size :

Type	AL5	AL10	AL25	AL50	AL100	AL200	AL300	AL500	AL750 ~ AL2000	AL3000 ~ AL5000
Area (CM ²)	60	100	225	225	2210	2210	2210	2210	3652	5000
Thickness (MM ²)	1	1	1.5	3	3	3	3	3	5	5

Marking:

The AL type the nominal resistance & tolerance are marked on the resistor body using

four coloured bands. OR marked using LEGEND marking; for e.g : KV-OHM

10E 10W J

Part Numbering Information:

Part Number : Type number, power rating, resistance value, tolerance, tcr.

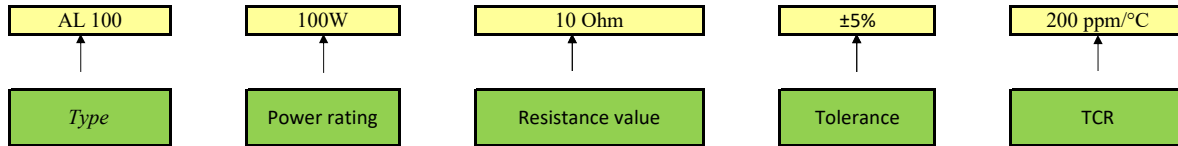

Examples: PART NO. : AL100, 100W, 10 Ohm, ±5%, 200ppm/°C

MATERIAL SPECIFICATIONS:

Element : Copper-nickel alloy or nickel-chrome alloy or fercal depending on resistance value

Core : Ceramic, steatite or alumina, depending on physical size

Encapsulant : Silicone cement construction

Housing : Aluminium with hard anodic coating (optional) golden/ silver.

Standard Terminals : Tinned copper wire/ss tag terminal

Performance Data (Procedure & Requirements):

TEST	PROCEDURE	REQUIREMENTS
Robustness Of Termination	Load 10N for AL5 ~ AL50 Load 20 N for AL100 ~ AL5000	No mechanical damage $\Delta R/R \text{ max.: } \pm(0.50\% + 0.05 \Omega)$
Temperature Cycling	30 minutes at -55°C & 30 minutes at 200°C Total 5 number of cycles.	No visual damage $\Delta R/R \text{ max.: } \pm(1.0\% + 0.05 \Omega)$
Short Time Overload	5 X Rated power for 5 sec. upto 10W size 10 X Rated power for 5 sec. from 25W size & above.	$\Delta R/R \text{ max.: } \pm(2.0 + 0.05 \Omega)$
Endurance @ 25°C	1000 hrs. load with Pn (power nominal) 1.5 hr. ON & 0.5 hr. OFF	No visual damage $\Delta R/R \text{ max.: } \pm(5.0\% + 0.1 \Omega)$
Temperature Rise Test	Horizontally mounted, loaded with Pn	Hot spot temperature less than maximum body temperature (275°C)
Damp Heat Steady State	56 days, 40°C; 90 to 95% Rh; dissipation $\leq 0.01P_n$	No visual damage $\Delta R/R \text{ max.: } \pm(5.0\% + 0.1 \Omega)$
Temperature Coefficient	At 25/-55/25 °C & 25/200/25 °C	Within specified limits
Insulation Resistance	1 minute duration At 500 V dc between case & terminal	$> 10^3 M\Omega$
Dielectric Strength	1000 V for AL5 to AL25, 1500V for AL25 to AL50, & 2000 V for AL100 to AL500, 2500 for AL600 to AL5000	No flashover $\Delta R/R \text{ max.: } \pm(0.5\% + 0.1 \Omega)$
Vibration	Frequenct range - 1 - 100 Hz Amplitude $\pm 1 \text{ mm @ } 0.7G$	$\Delta R/R \text{ max : } \pm 1\%$

Derating Curve:

